

Pore and Field Scale Computational Simulation of CO₂ Subsurface Storage

Shruti Malik, Parsa Alimohammadiardakani, Zaid Jangda, Hannah P.
Menke, Mayur Pal



Introduction

CO₂ Storage Opportunities In Baltic Region

Baltic basin extends in countries such as Lithuania, Latvia, and Estonia, having several hydrocarbon and deep saline reservoirs in offshore and onshore settings.

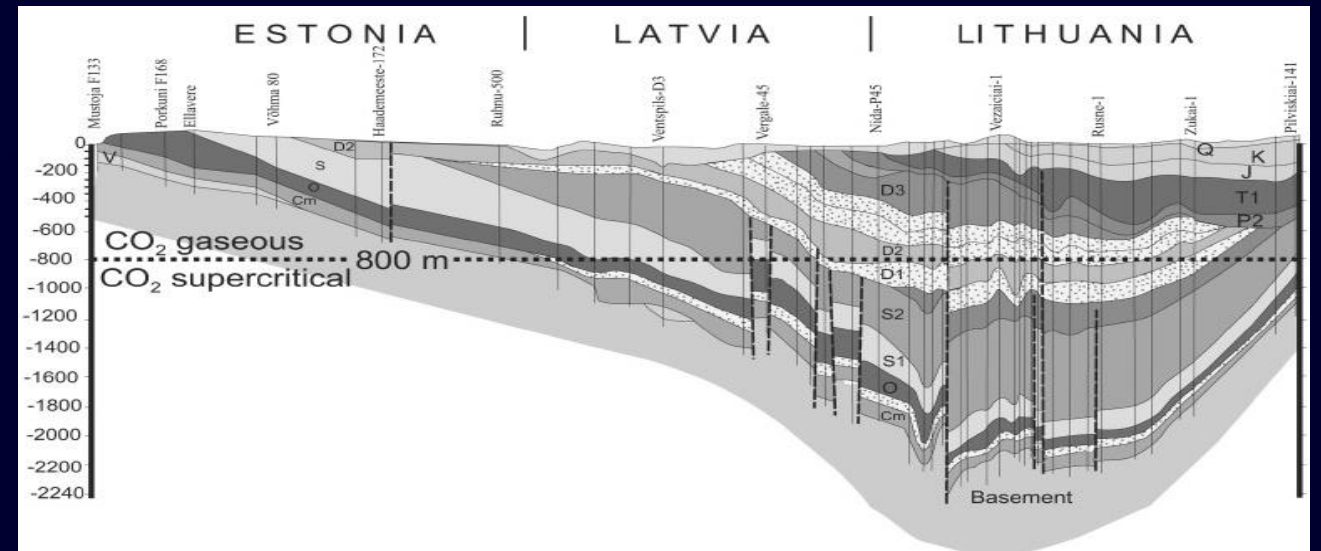
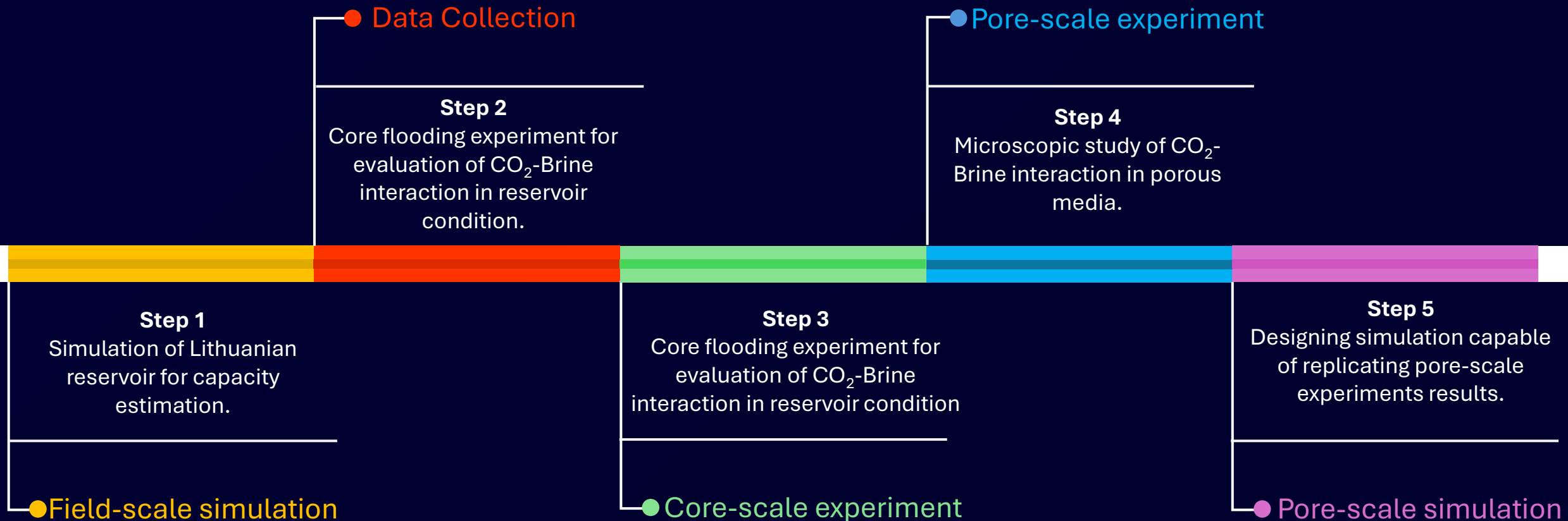

Figure. Baltic reservoir map (Shogenova et al., 2009)

Research Chronological Order



Introduction

CO₂ Storage Capacity of Lithuanian Reservoirs

Reservoir	Cases		
	Low	Mid	High
Syderiai Saline Aquifer (Mt)	54	80	232
Vaskai Saline Aquifer (Mt)	25	37	106
Gargzdai Oil Zone (Mt)	64	94	267

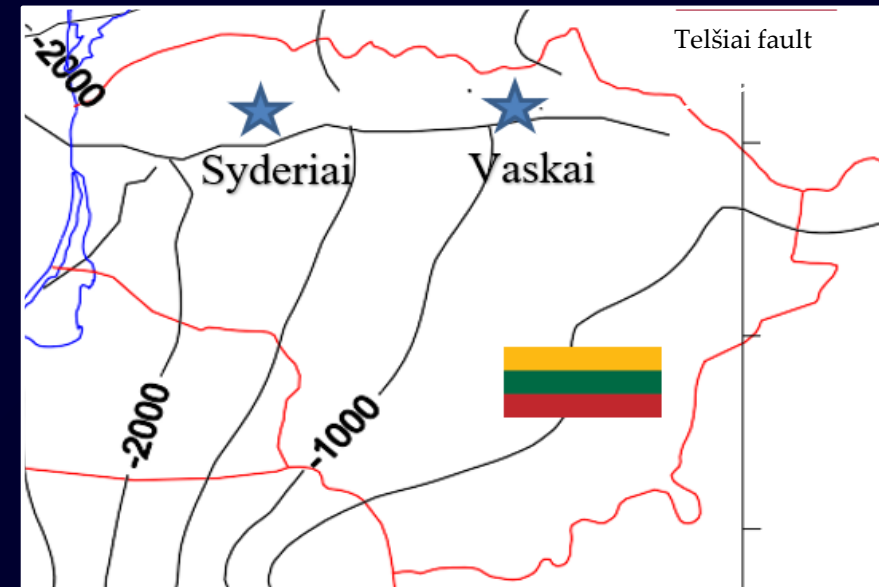
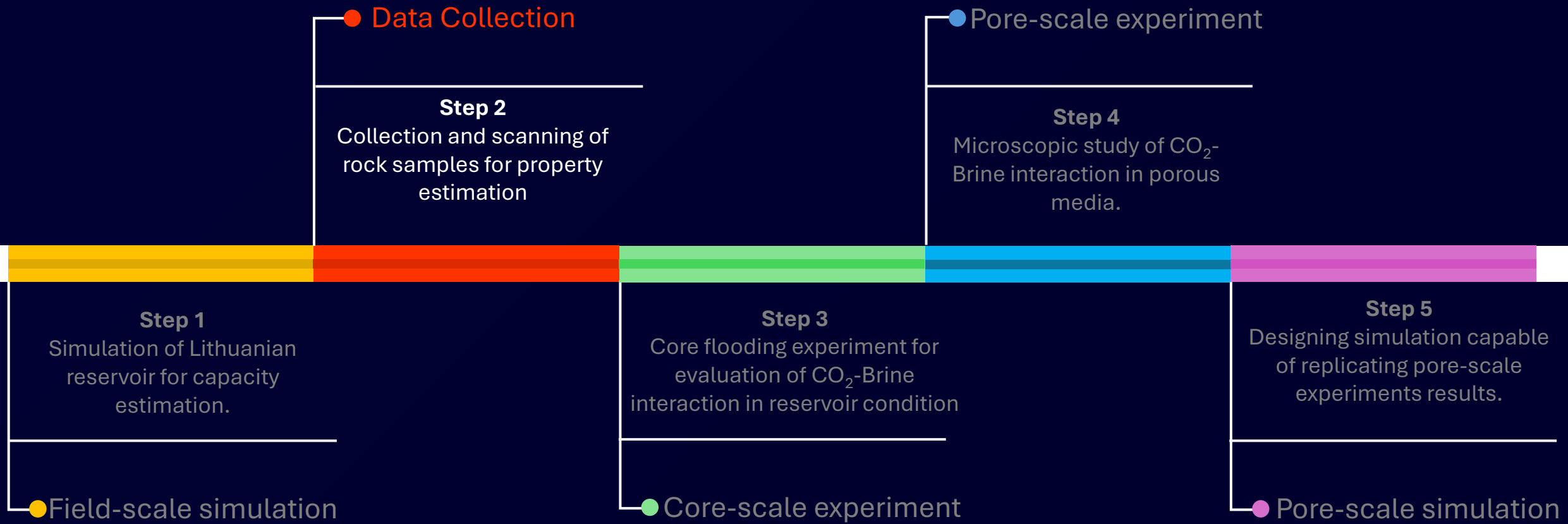

Figure. Location of saline aquifers of Lithuania, Syderiai and Vaskai. The depth contours indicate the top depth of the Cambrian structures (Malik et al., 2024).

Table. CO₂ storage volume of different Lithuanian reservoirs after 30 year injection (Malik et al., 2024).

Research Chronological Order



Data Collection

Lithuanian reservoir samples



Syderiai saline aquifer



Vaskai saline aquifer



P-Šiūpariai hydrocarbon reservoir



Vilkyčiai hydrocarbon reservoir

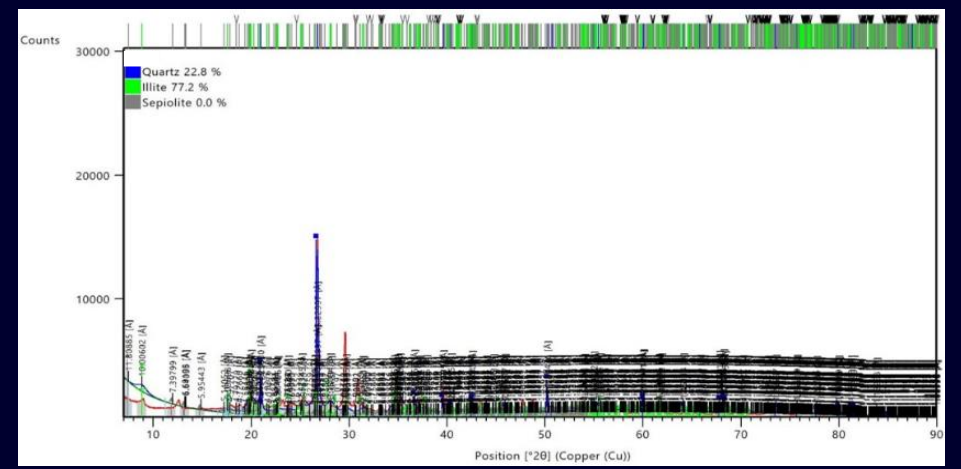
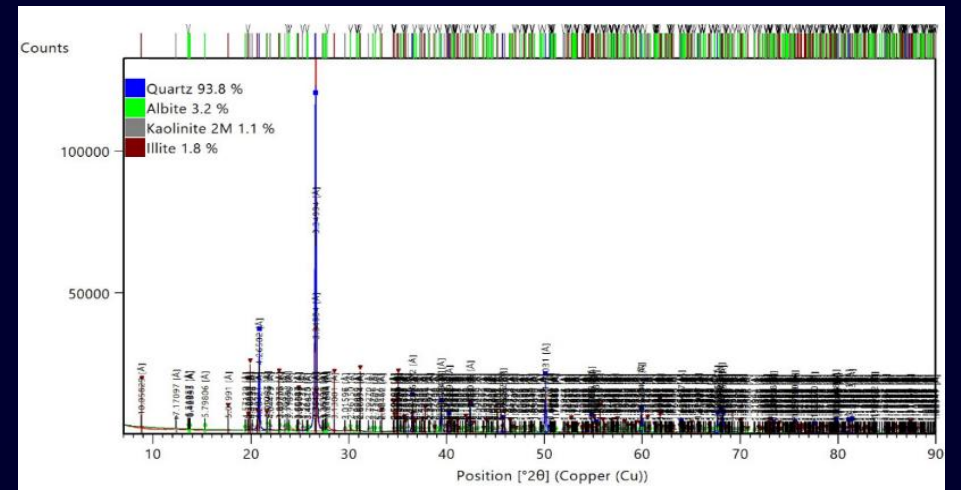

Data Collection

Outcrop samples: analogous to Lithuanian reservoirs

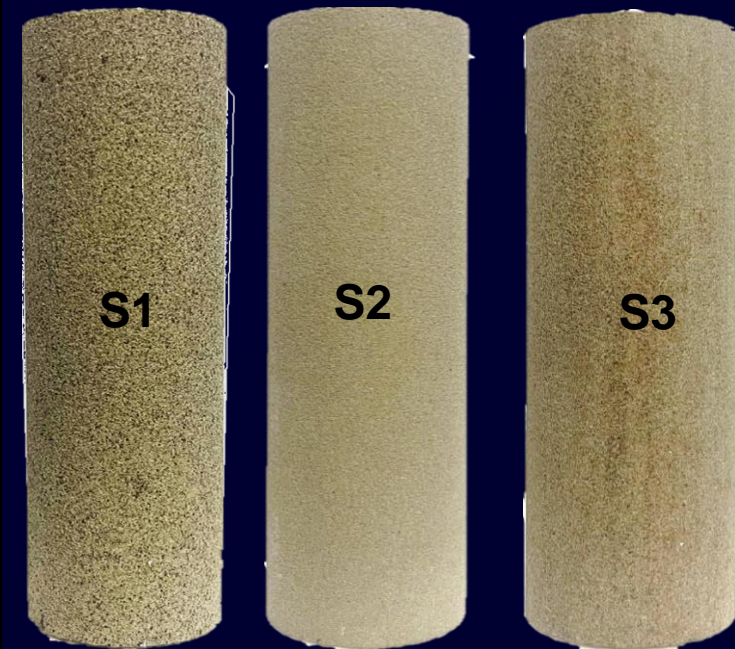

Sample Name	Length (cm)	Diameter (cm)	Pore volume (cm ³)	Porosity (%)	Permeability (mD)
S1	15.245	3.775	36.899	21.60	218
S2	15.259	3.761	34.424	20.28	21
S3	15.234	3.797	34.573	20.06	61

Research Chronological Order

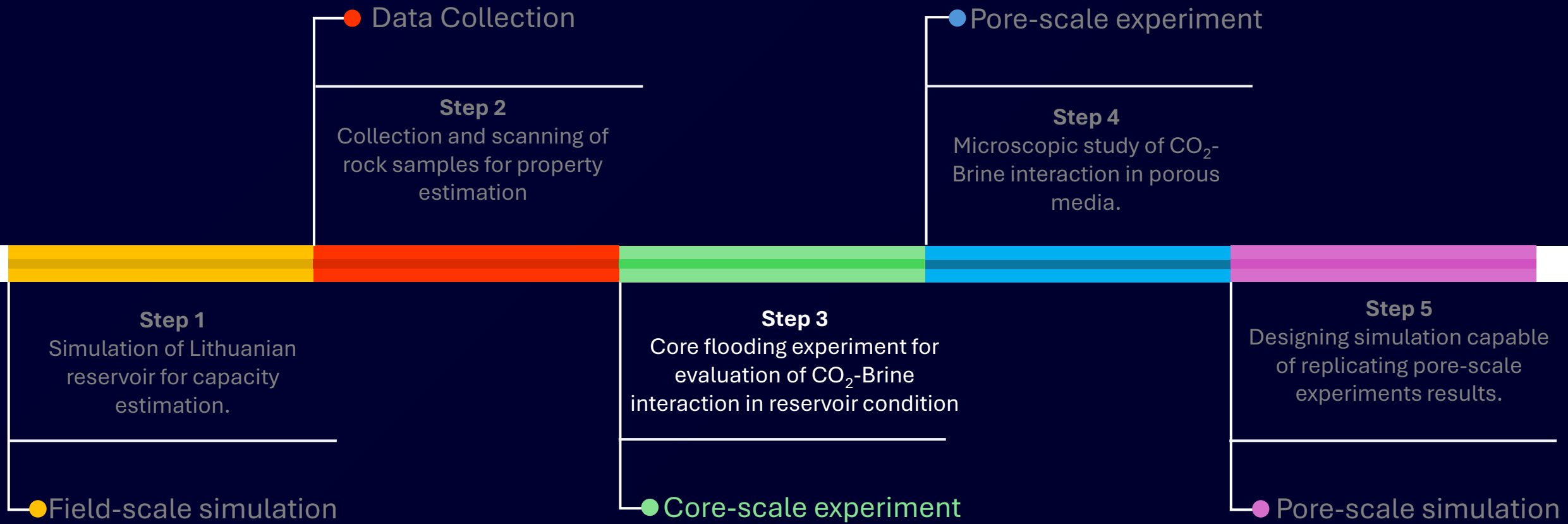

Rationale : Core Flooding Experiment

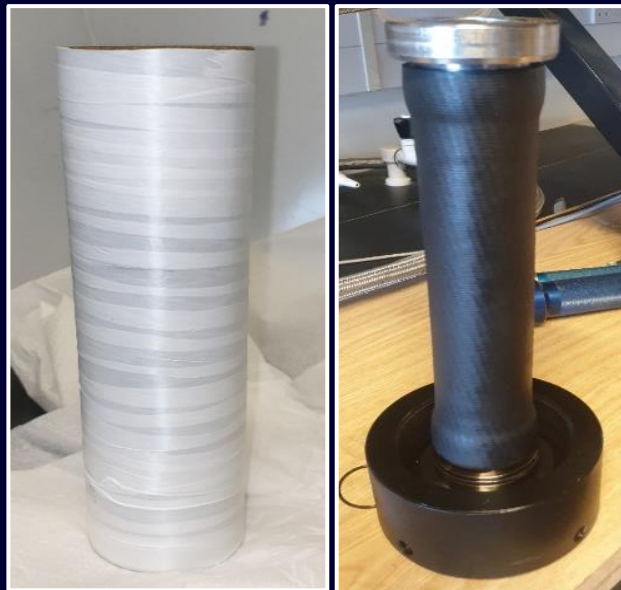

Figure. Preparation of core sample for core flooding.

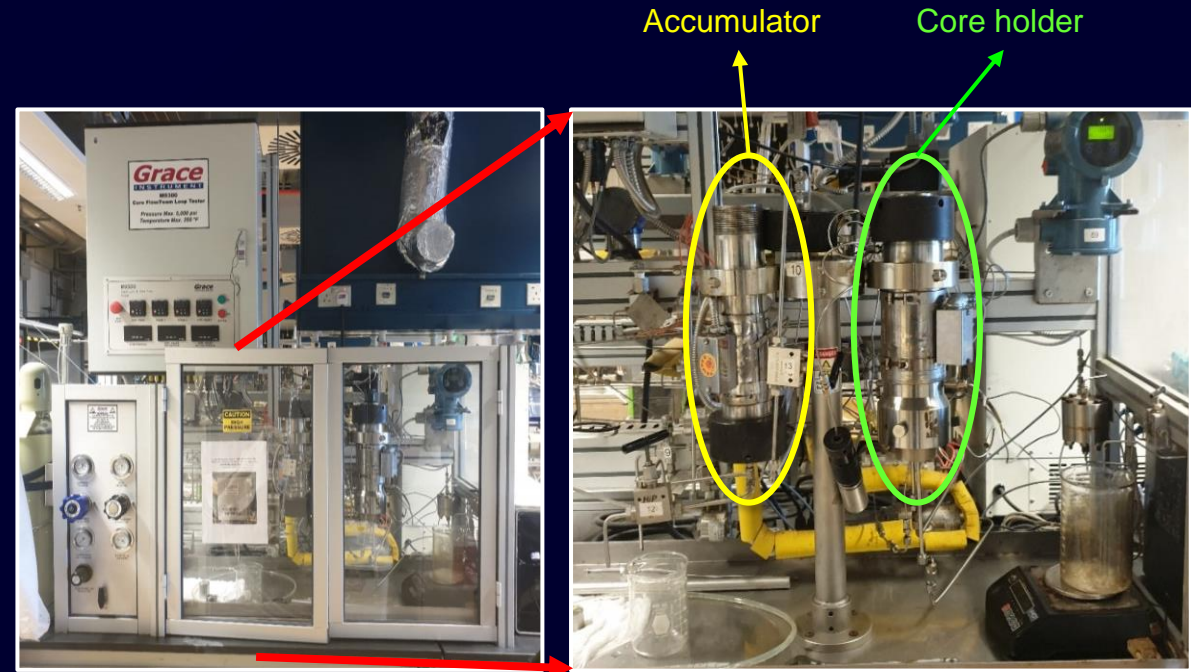

Figure. Core flooding experiment setup.

Rationale : Core Flooding Experiment

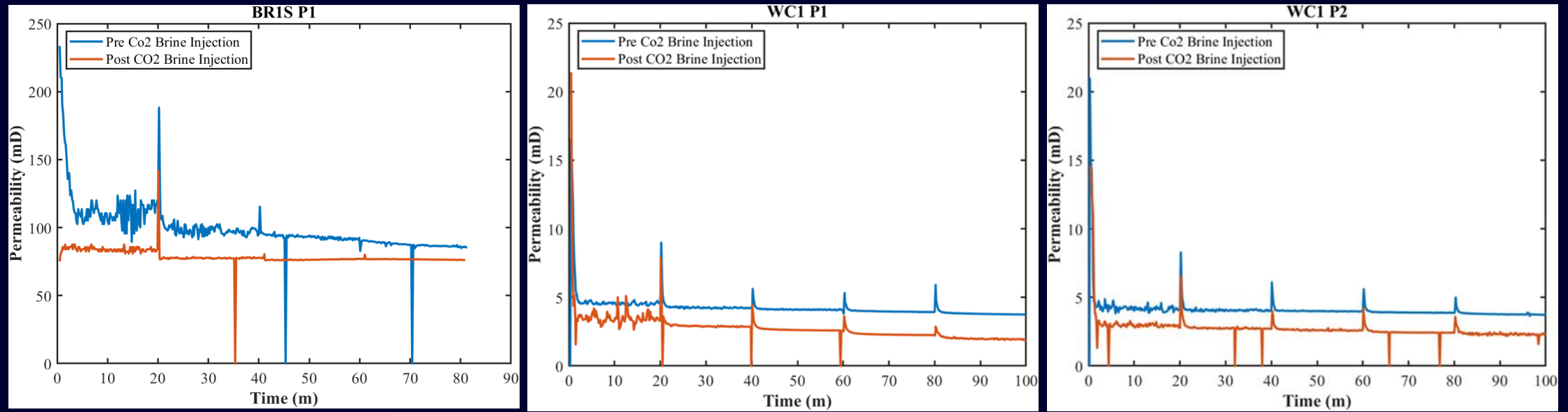

Figure. Change in permeability of cores due to CO₂ injection.

Rationale : SEM Imaging

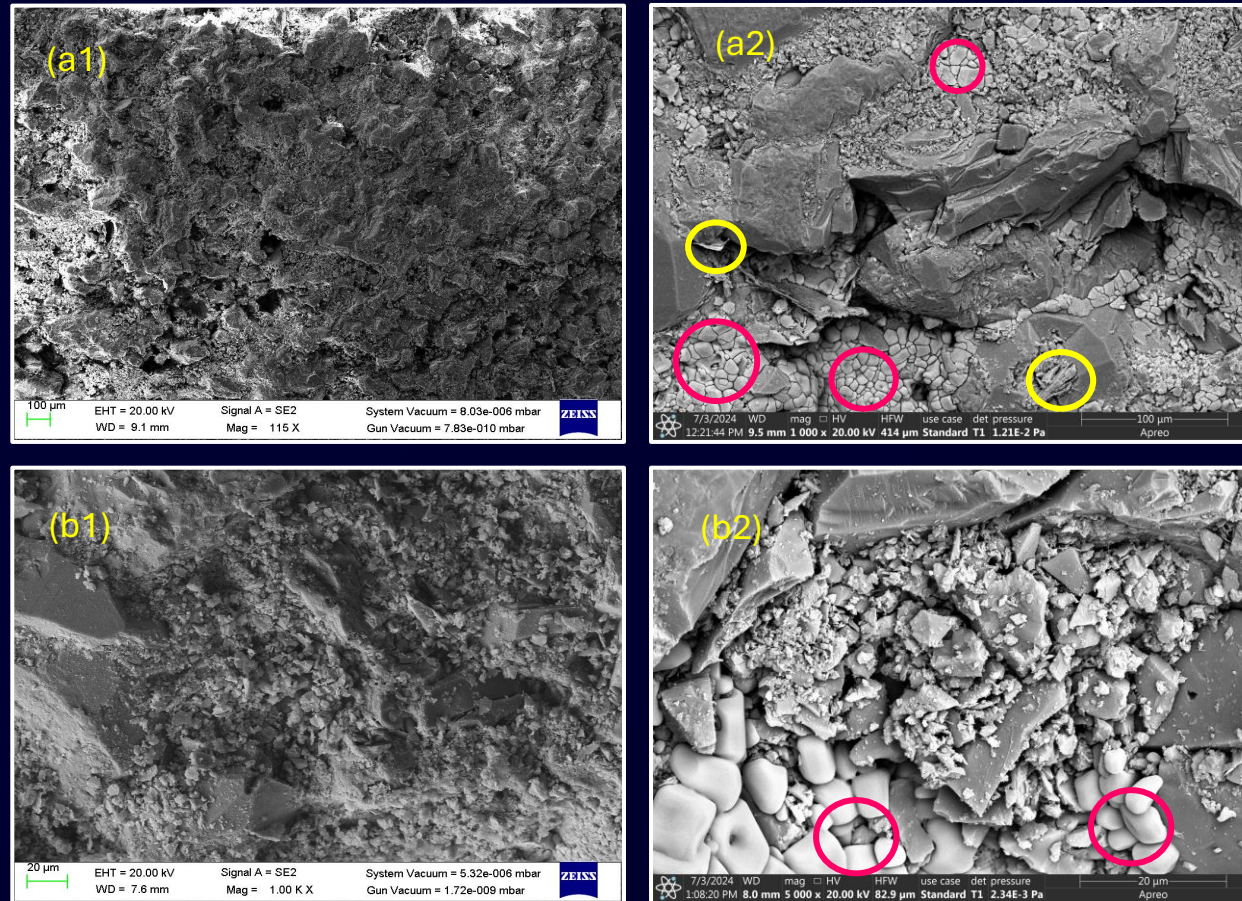
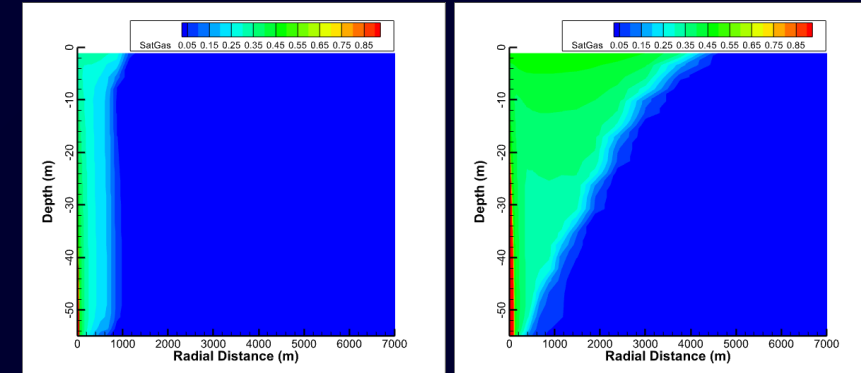

Figure. Formation of salts crystals inside rock porous structure.

Rationale : Gaps in Simulation Accuracy

Simulation in TOUGHREACT



a) 10 years

a) 100 years

Figure. Change in Gas Saturation.

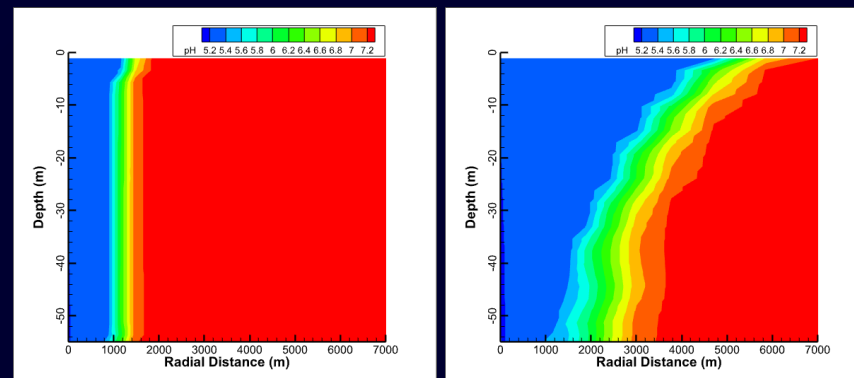

a) 10 years

a) 100 years

Figure. Change in pH.

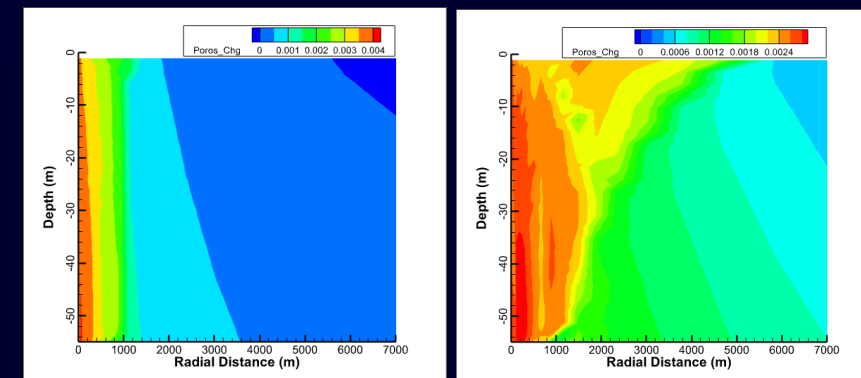

a) 10 years

a) 100 years

Figure. Change in porosity.

Research Chronological Order

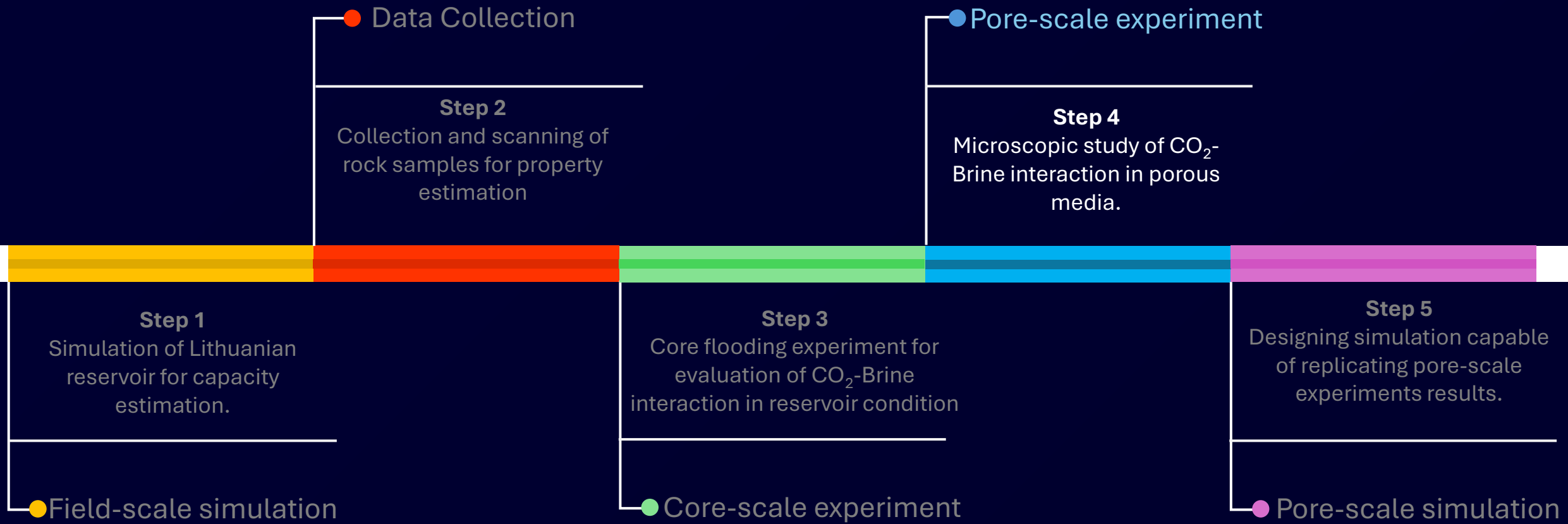

Introduction

Significance of Pore-Scale Understanding in Subsurface Processes

- Captures the fundamental physics of fluid flow and transport in porous media.
- Improves accuracy of continuum-scale models through realistic upscaling.
- Helps perform risk assessment associated with CO₂ storage
 - Leakage and caprock integrity: Provides insights into multiphase flow, wettability, and capillary effects.
 - Enables better prediction of injectivity in subsurface reservoirs and storage capacity.
- Supports design and optimization of CO₂ sequestration, and groundwater remediation.
- Helps explain heterogeneity and anisotropy in rock and soil properties.
- Bridges the gap between experimental observations and numerical simulations.

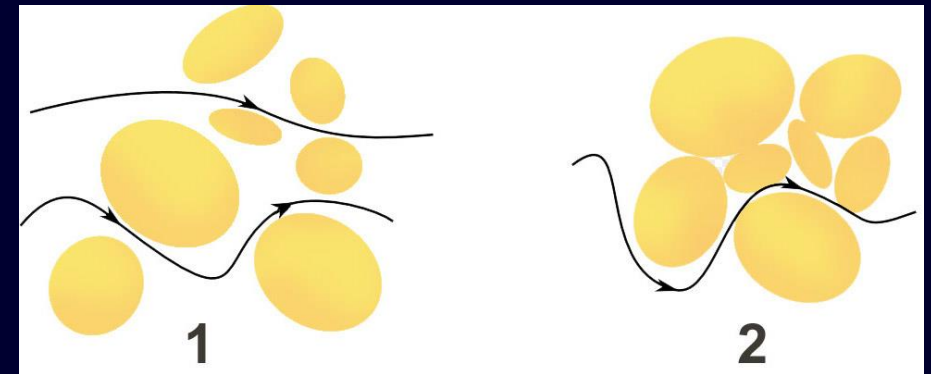
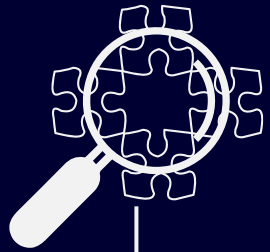

Figure. Flow inside Porous media
(https://en.wikipedia.org/wiki/Porous_medium).



Figure. Core samples

Experiment Design Steps



Rationale

Identifying the gaps, needs, or missing parts that motivate the study.



Objectives

Defining the key questions or problems to be addressed.

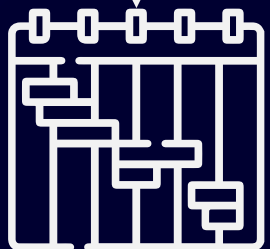

Design & Planning

Structuring the experiment and planning methods to meet the objectives.



Path Forward

Outlining future steps, improvements, and directions to advance the research.



Results & Analysis

Assessing outcomes and interpreting the experimental findings.



Methodology

Executing the experimental steps and procedures.

Investigate CO₂-Brine Interactions at the Pore Scale

Determine Optimal Conditions for Salt Precipitation
During CO₂ Injection

Develop and Validate Simulations Reflecting Observed
Behaviors

Experiment Design : Setup

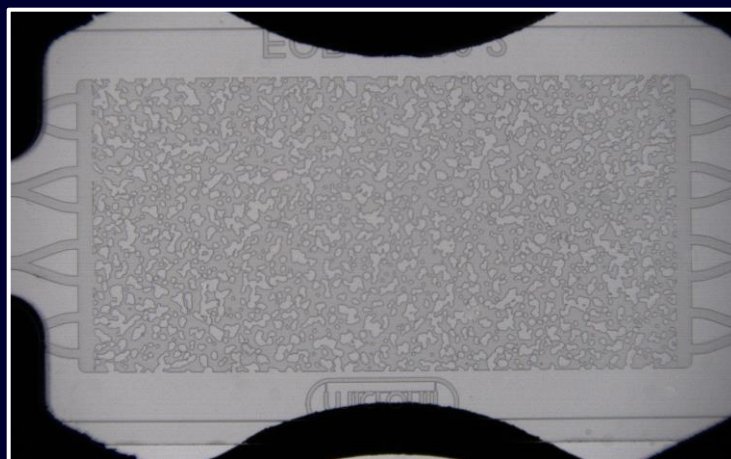
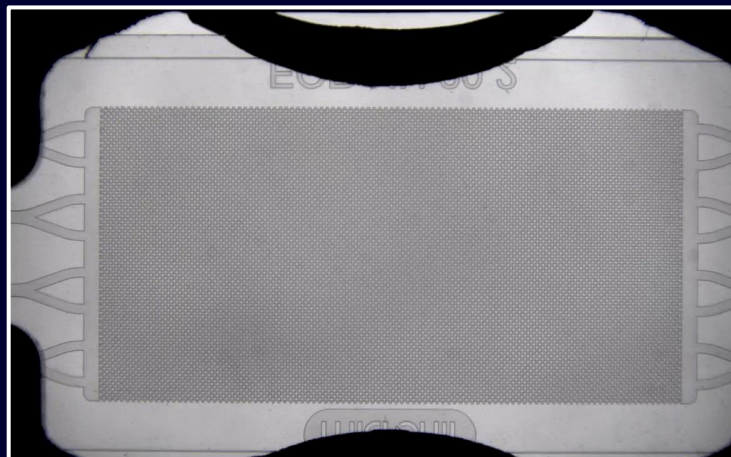

Figure. microfluidic setup.

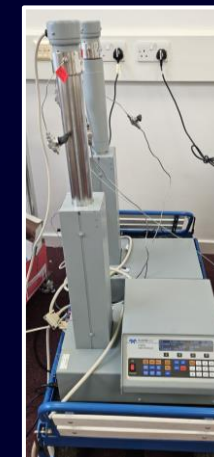

Figure. Experiment setup (@ Heriot Watt University).

Experiment Procedure (Methodology)

- **Brine Preparation**
- Pre-Experimental Preparation
 - Regulator
 - ISCO Pump
- System Air-Flush
- Microscope Observation
- Chipset Cleaning

Lithuania Salinity - g/L of solution		High Saline Reservoir - g/L of solution
120	180	250

Table. salinity of the brines used in the experiments.

Experiment Procedure (Methodology)

- Brine Preparation
- **Pre-Experimental Preparation**
 - Regulator
 - ISCO Pump
- System Air-Flush
- Microscope Observation
- Chipset Cleaning

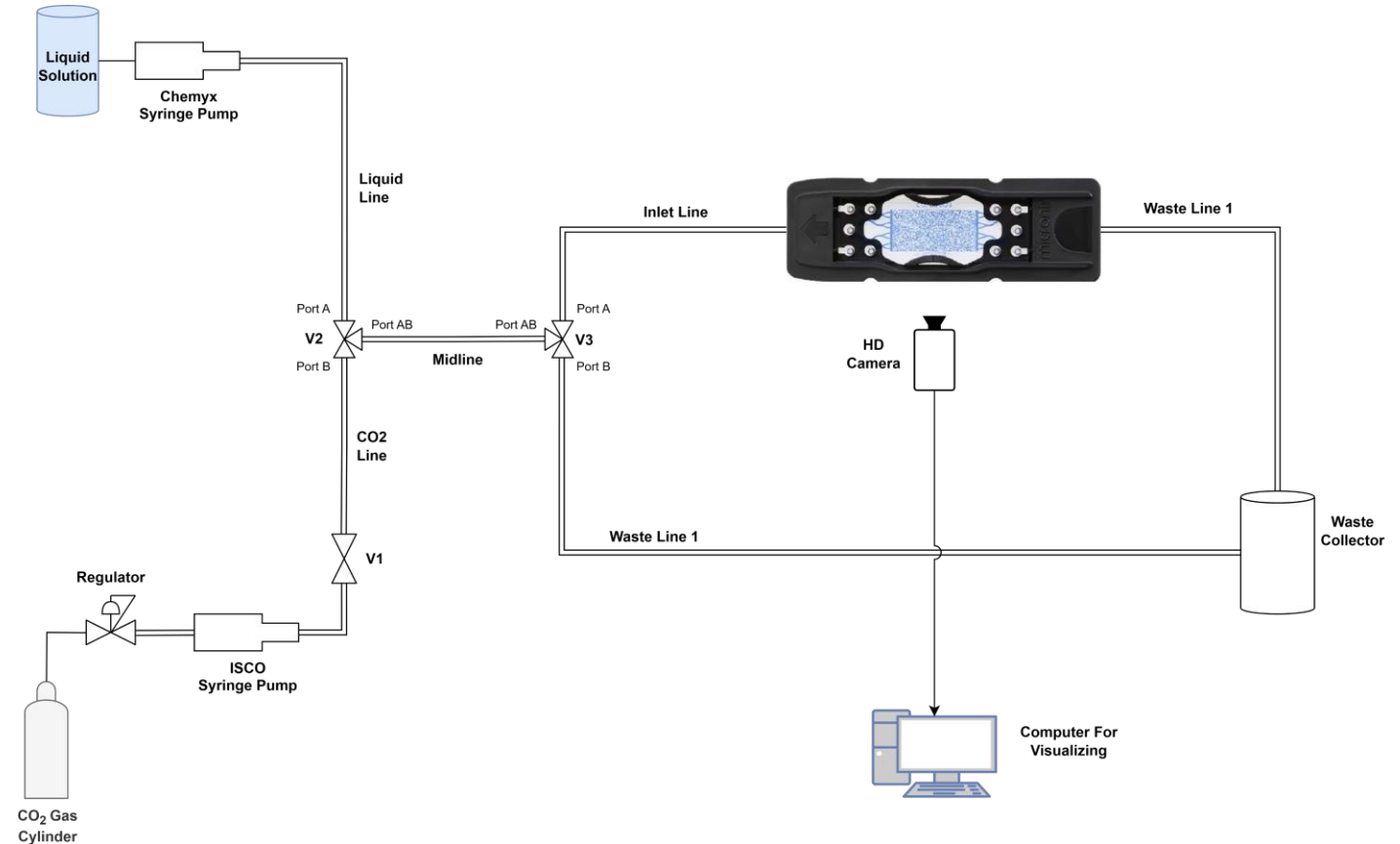

Figure. the schematic of the experiment setup.

Experiment Procedure (Methodology)

- Brine Preparation
- **Pre-Experimental Preparation**
 - Regulator
 - ISCO Pump
- System Air-Flush
- Microscope Observation
- Chipset Cleaning



Figure. ISCO pump machine and CO₂ gas with its regulator.

Experiment Procedure (Methodology)

- Brine Preparation
- Pre-Experimental Preparation
 - Regulator
 - ISCO Pump
- **System Air-Flush**
- Microscope Observation
- Chipset Cleaning

Experiment Procedure (Methodology)

- Brine Preparation
- Pre-Experimental Preparation
 - Regulator
 - ISCO Pump
- System Air-Flush
- **Microscope Observation**
- Chipset Cleaning



Figure. Microscopic photography.

Experiment Procedure (Methodology)

- Brine Preparation
- Pre-Experimental Preparation
 - Regulator
 - ISCO Pump
- System Air-Flush
- Microscope Observation
- **Chipset Cleaning**



Figure. Vacuum heating chamber.

Results

Brine Injection



Homogenous porous network.



Heterogenous porous network.

Results

CO₂ Injection

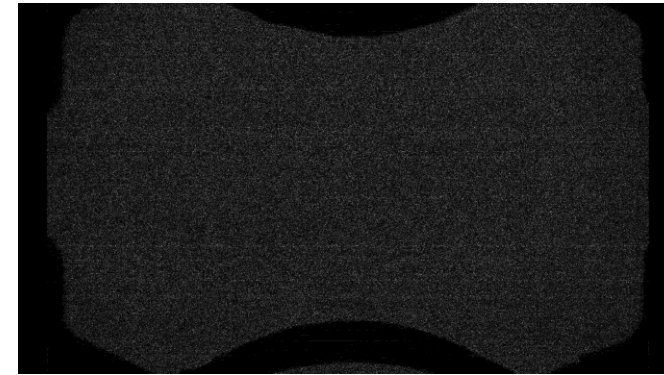
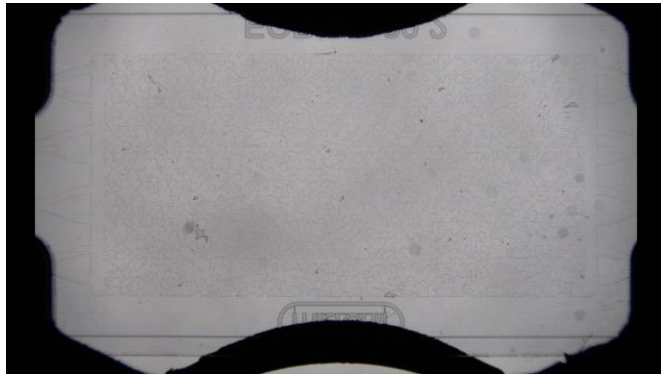

Figure. Heterogenous porous network.

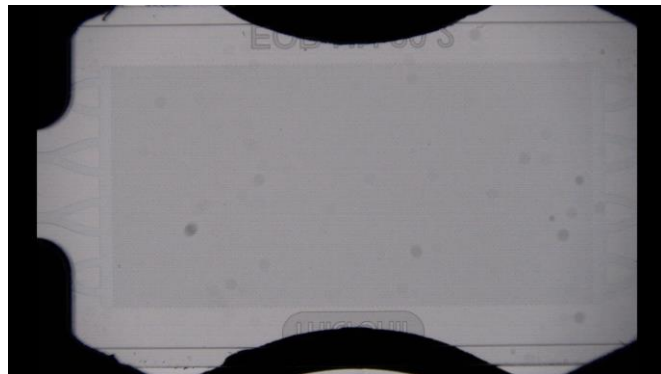
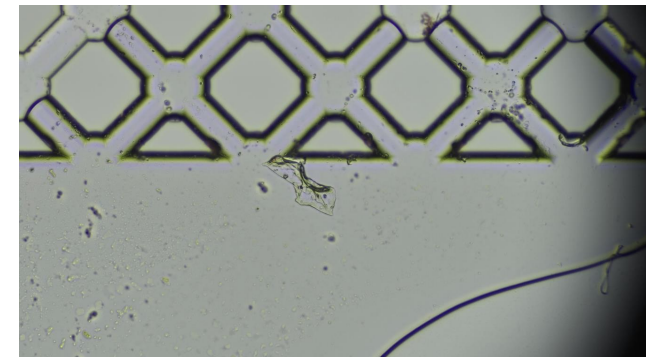
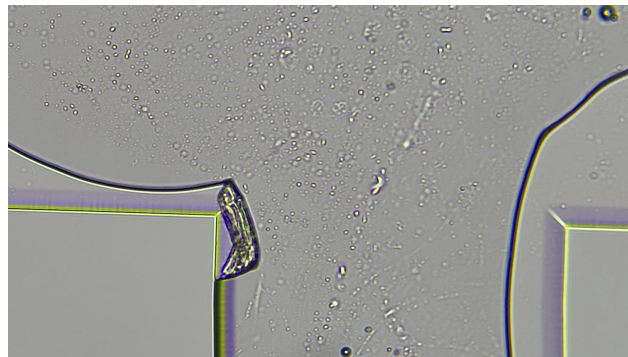
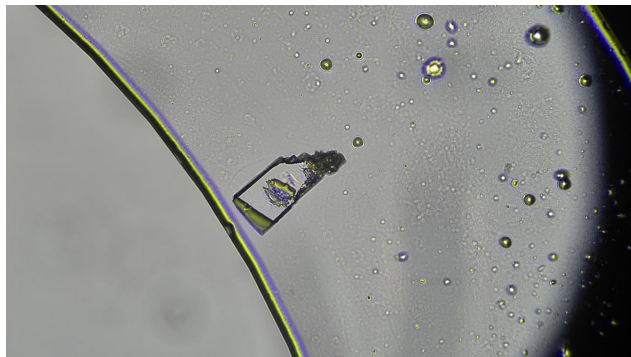

Figure. Homogenous porous network.

Results

Salt Crystals Formation



Results

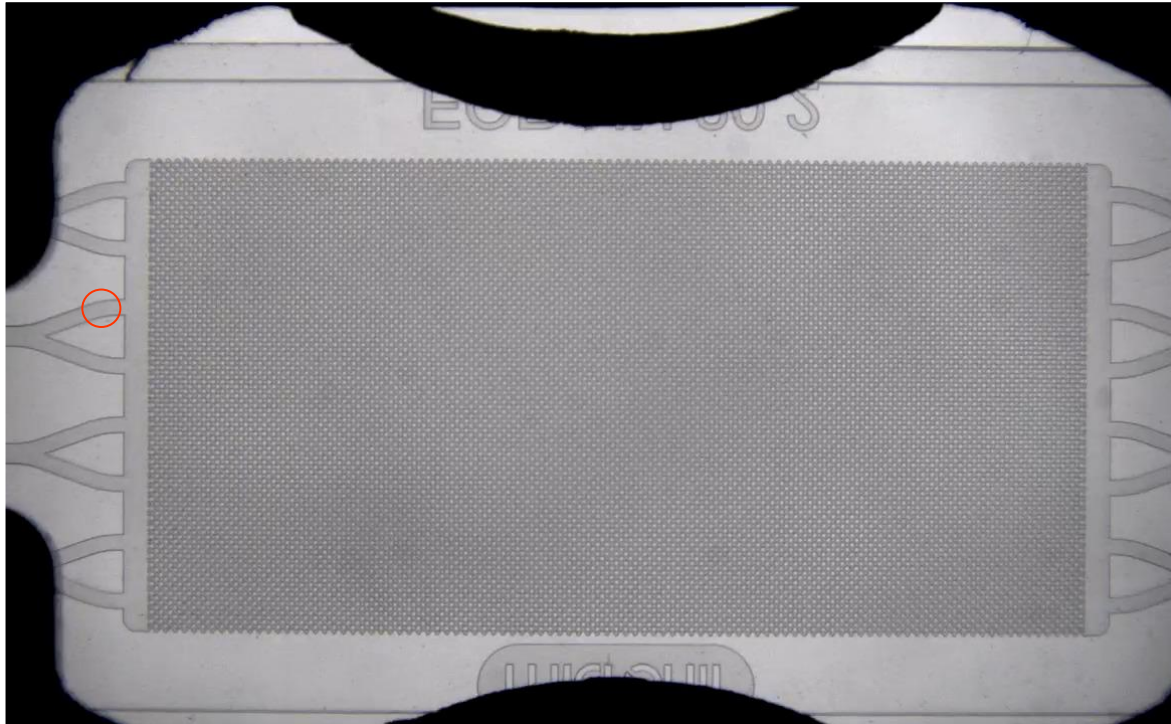

Figure. Homogenous porous map.

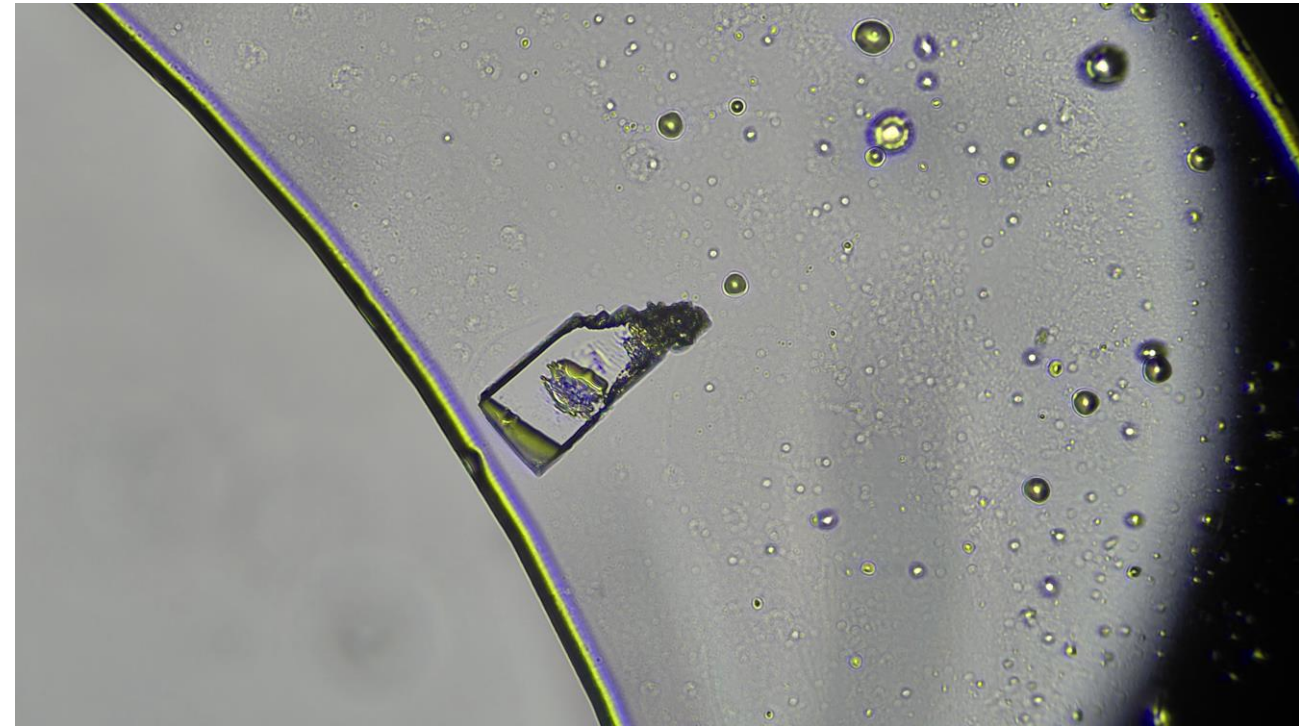

Figure. Formation of salt crystals.

Results

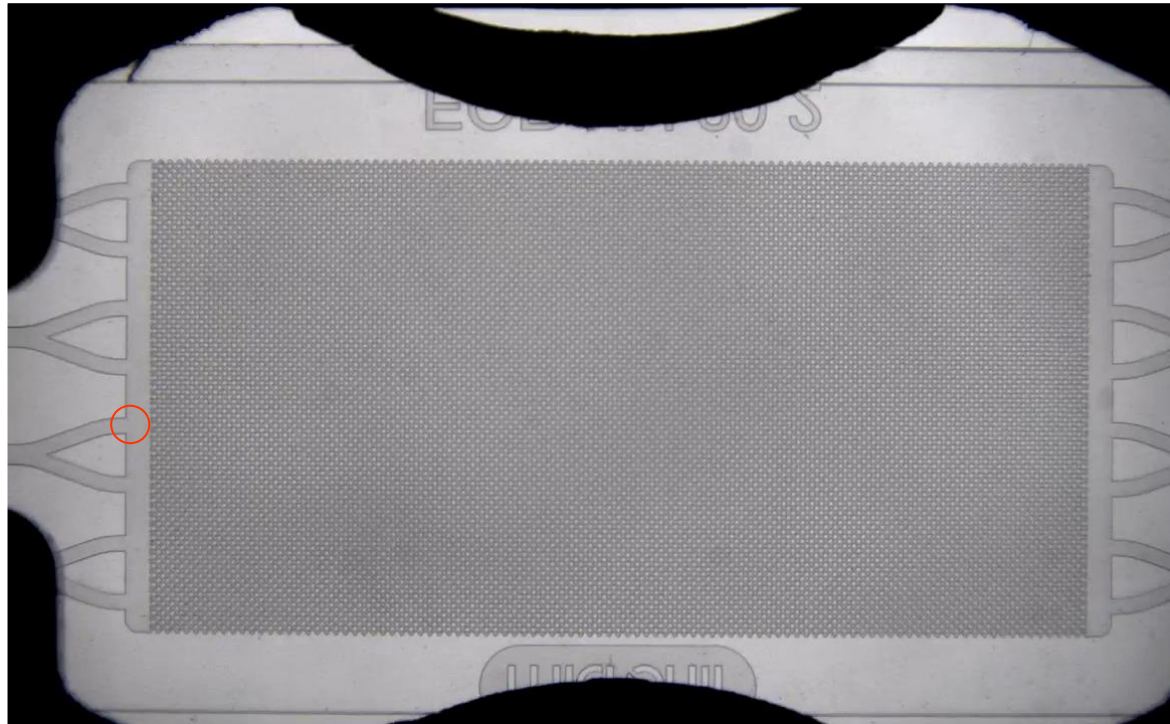

Figure. Homogenous porous map.

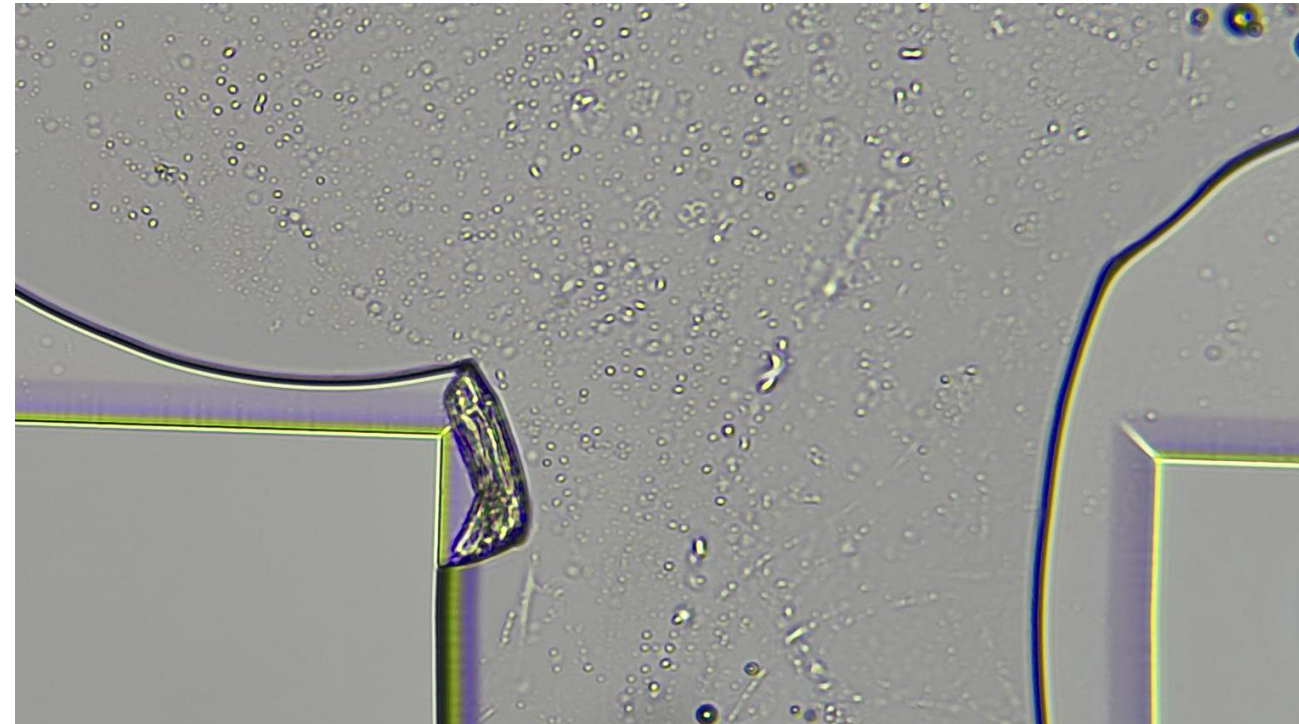

Figure. Formation of salt crystals.

Results

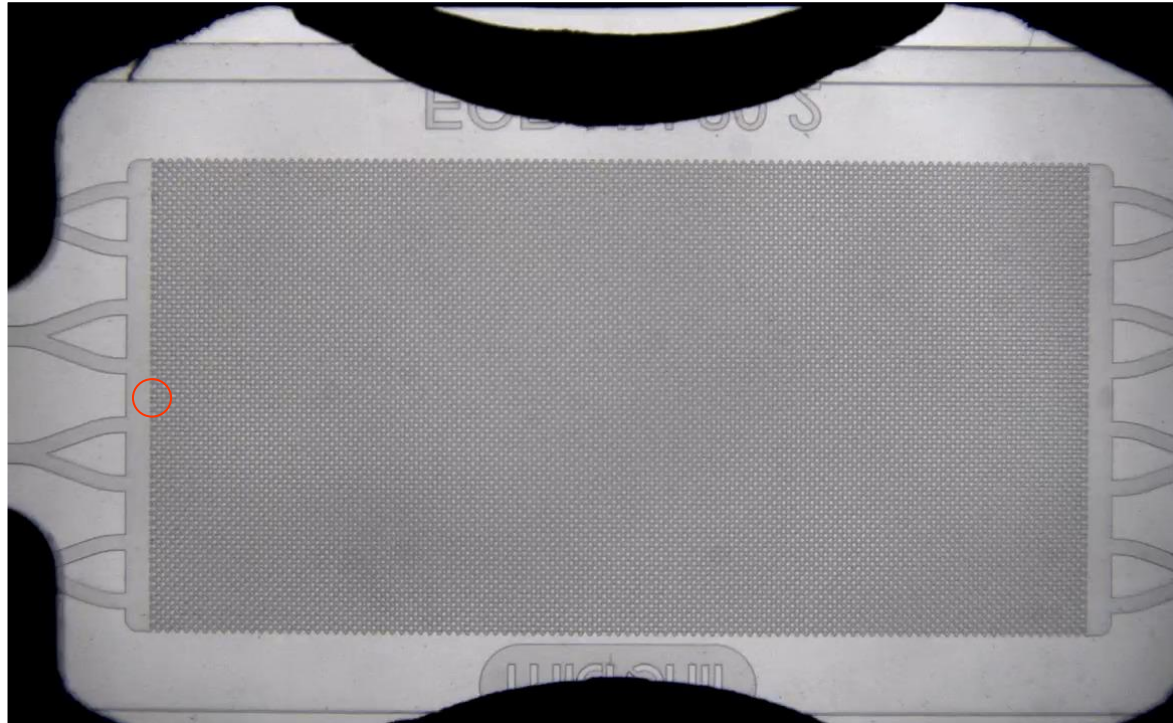

Figure. Homogenous porous map.

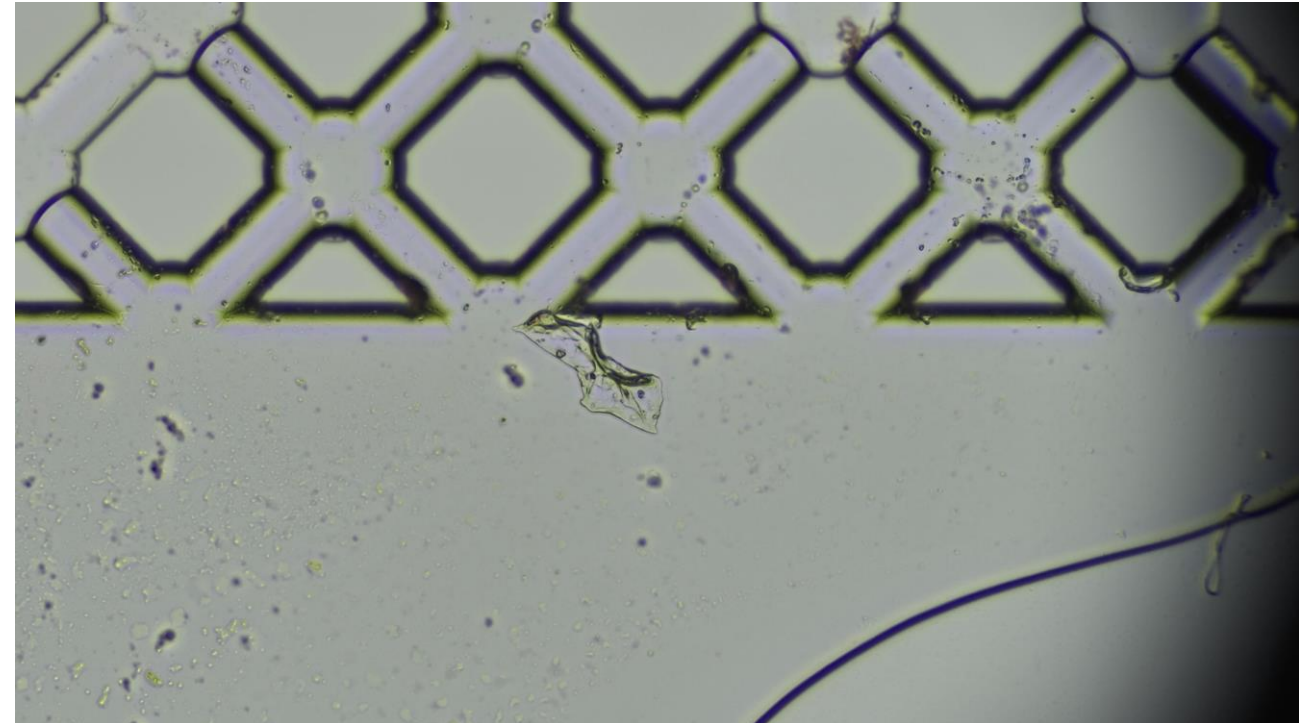

Figure. Formation of salt crystals.

Challenges And Fails

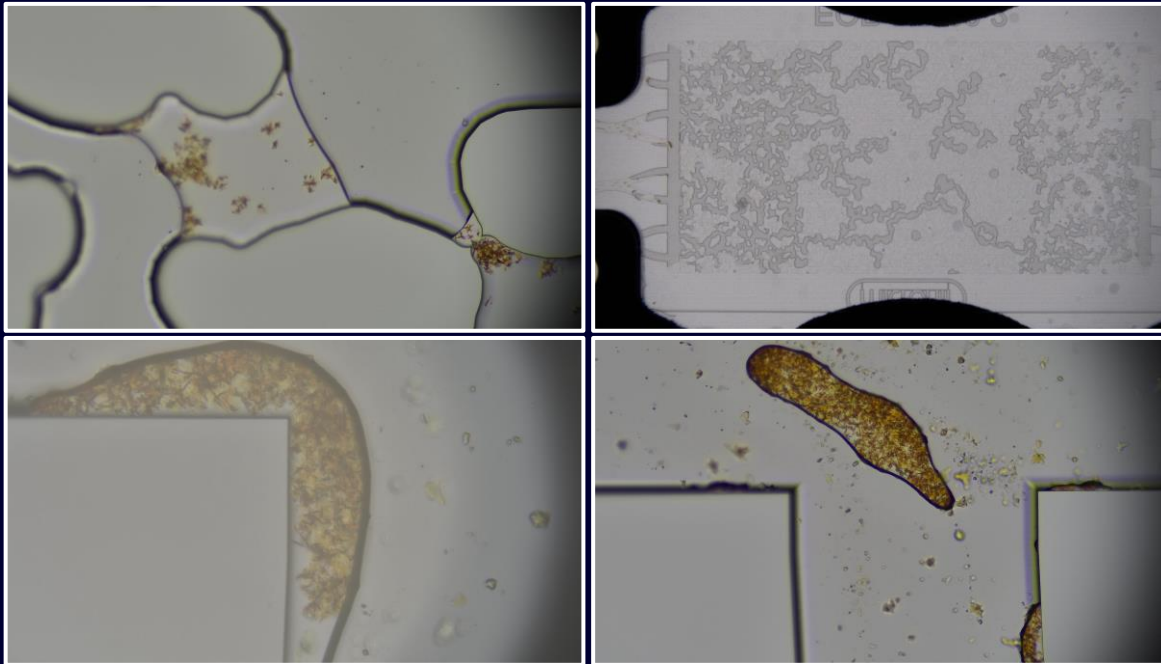

Figure. precipitation of dye after CO₂ injection.

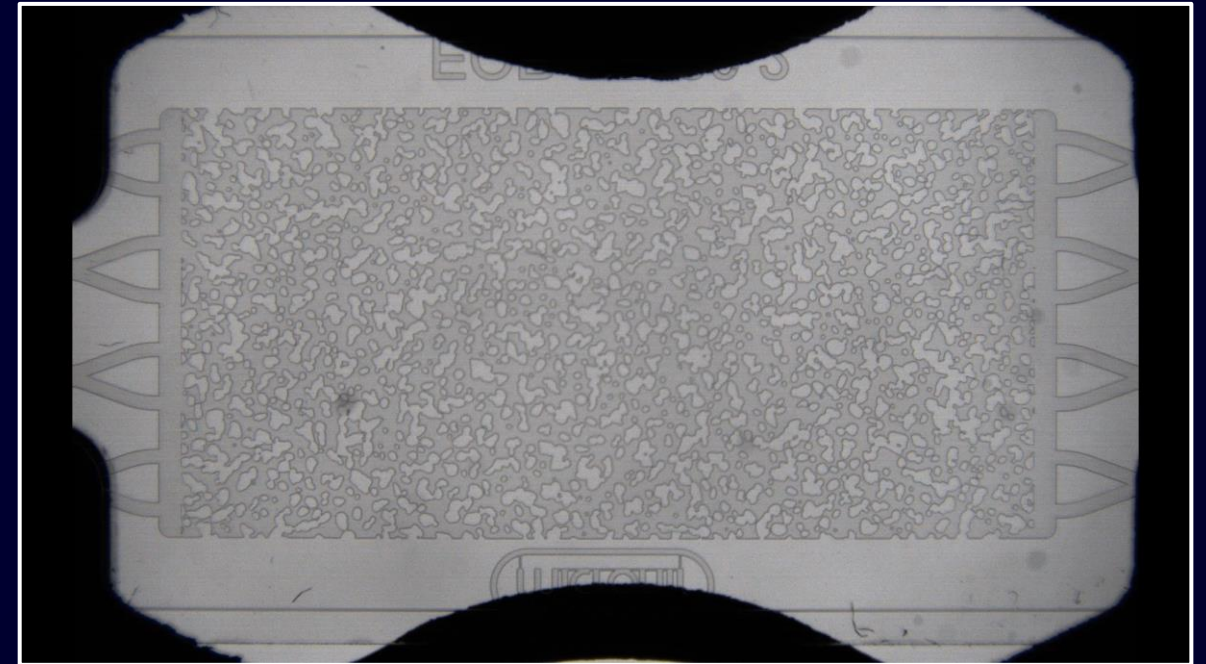
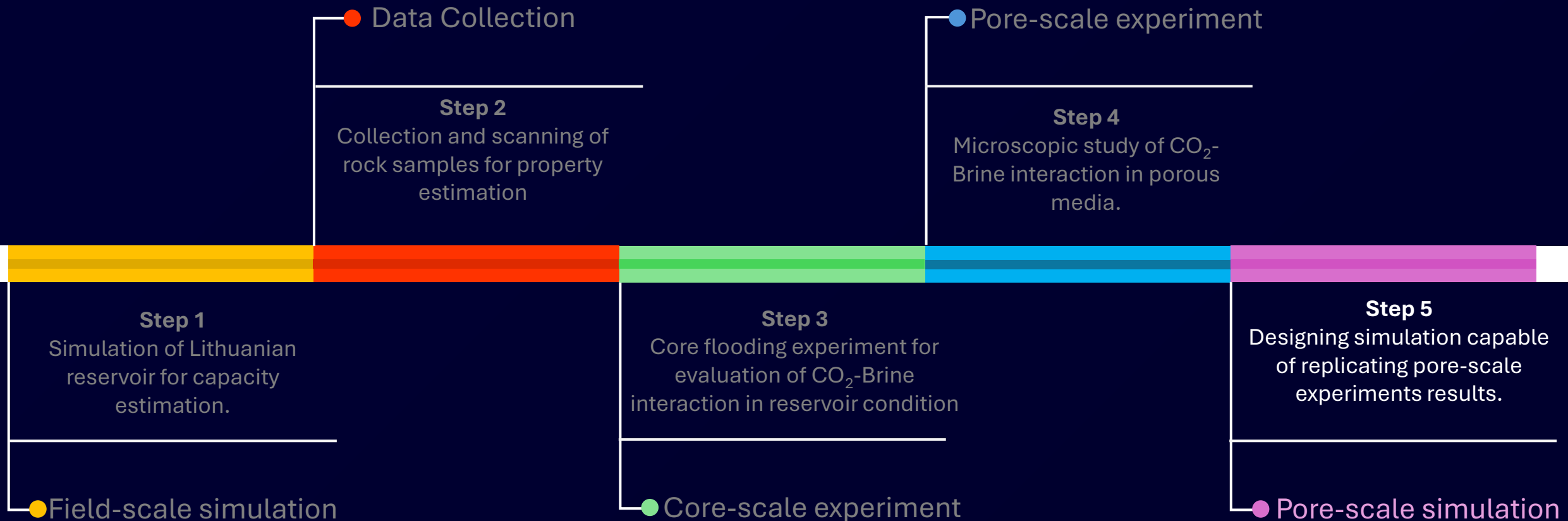

Figure. Failed air flushing. Pipes are not properly cleaned.

Research Chronological Order



MRST Simulation Workflow

- Porous Map Generation
- Color Code Mapping
- Porosity and Permeability Map Generation
- Fluids and Initial Conditions
- Simulation

MRST Simulation Workflow

- **Porous Map Generation**
- Color Code Mapping
- Porosity and Permeability Map Generation
- Fluids and Initial Conditions
- Simulation

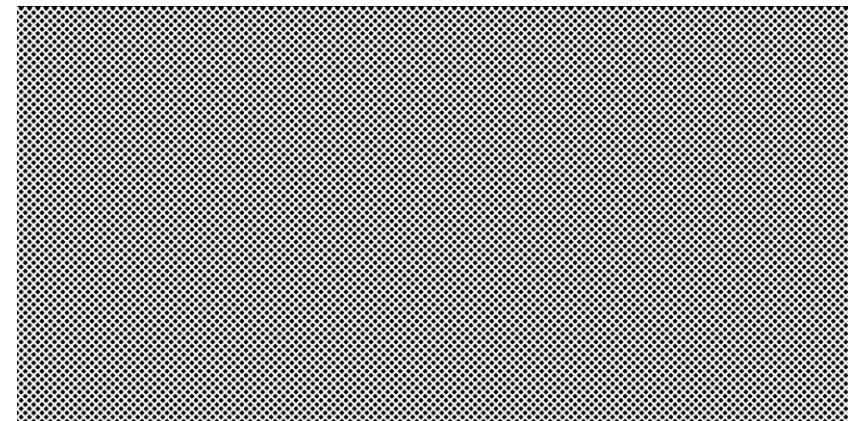
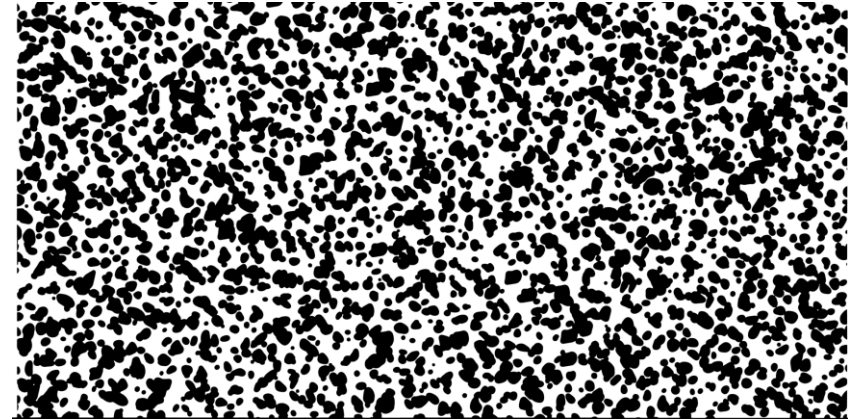

Heterogenous and Heterogenous porous network.

MRST Simulation Workflow

- Porous Map Generation
- **Color Code Mapping**
- Porosity and Permeability Map Generation
- Fluids and Initial Conditions
- Simulation

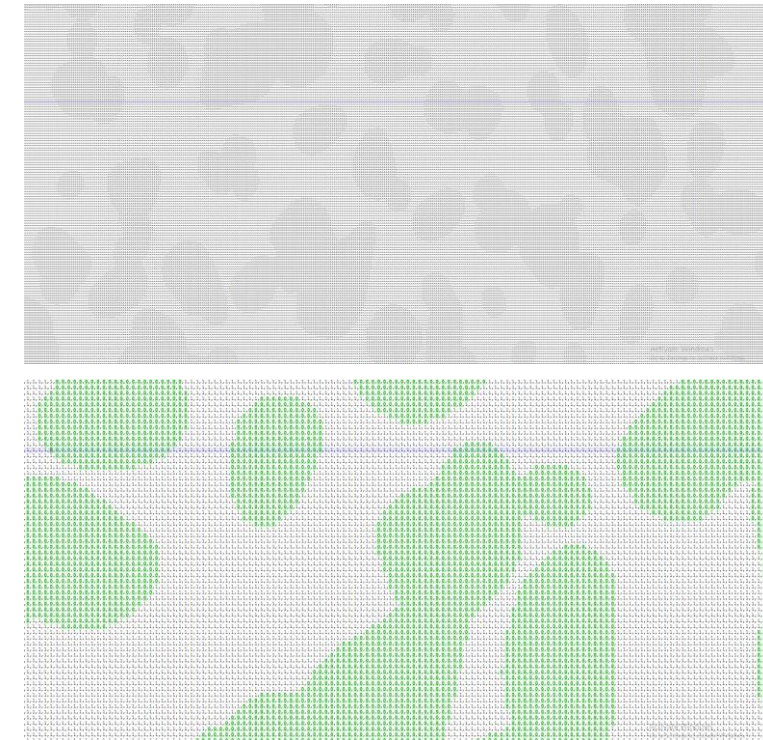
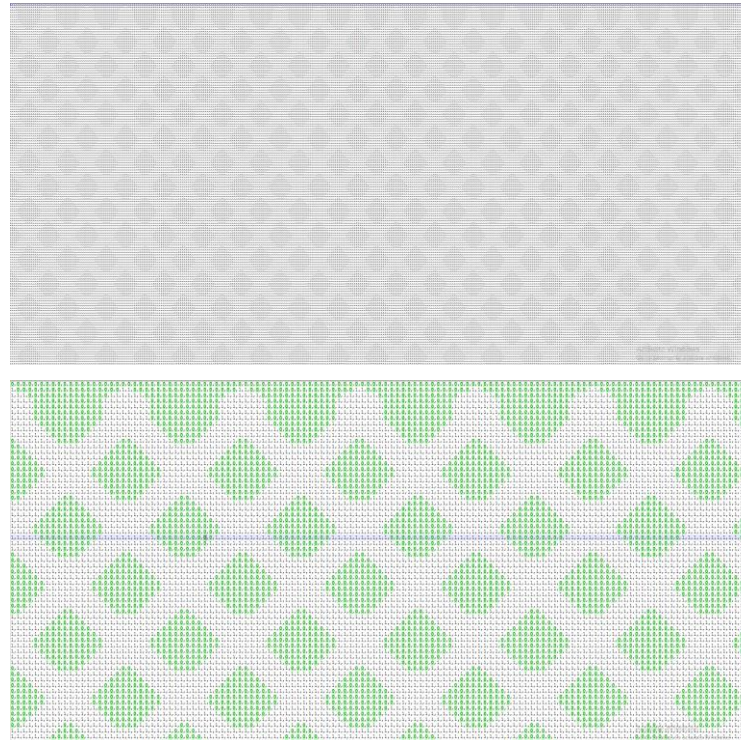

Simulation

MRST Simulation Workflow

- Porous Map Generation
- Color Code Mapping
- **Porosity and Permeability Map Generation**
- Fluids and Initial Conditions
- Simulation

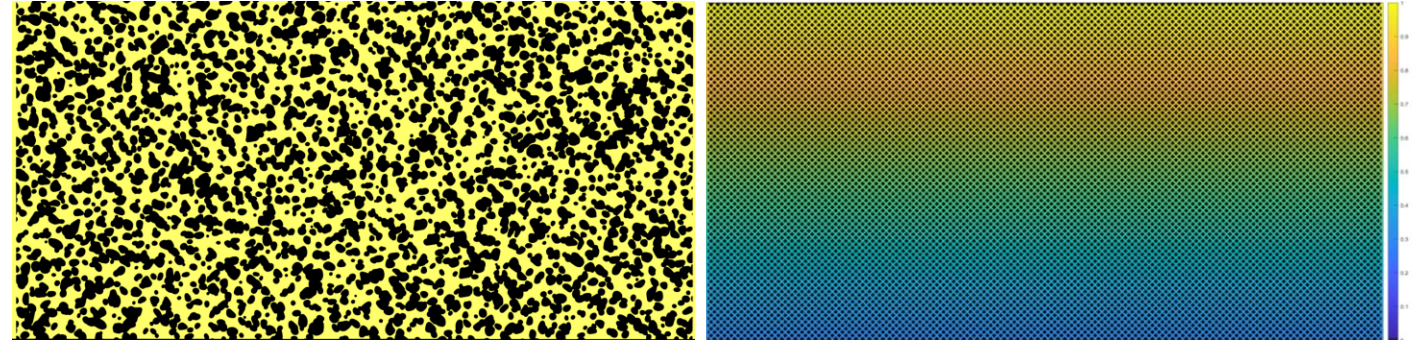

Permeability heatmap

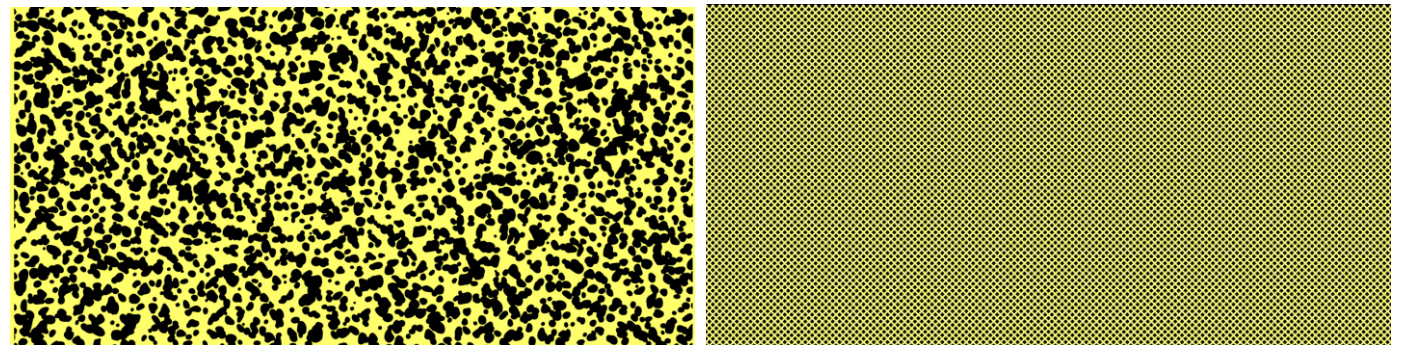

Porosity heatmap

MRST Simulation Workflow

- Porous Map Generation
- Color Code Mapping
- Porosity and Permeability Map Generation
- **Fluids and Initial Conditions**
- Simulation

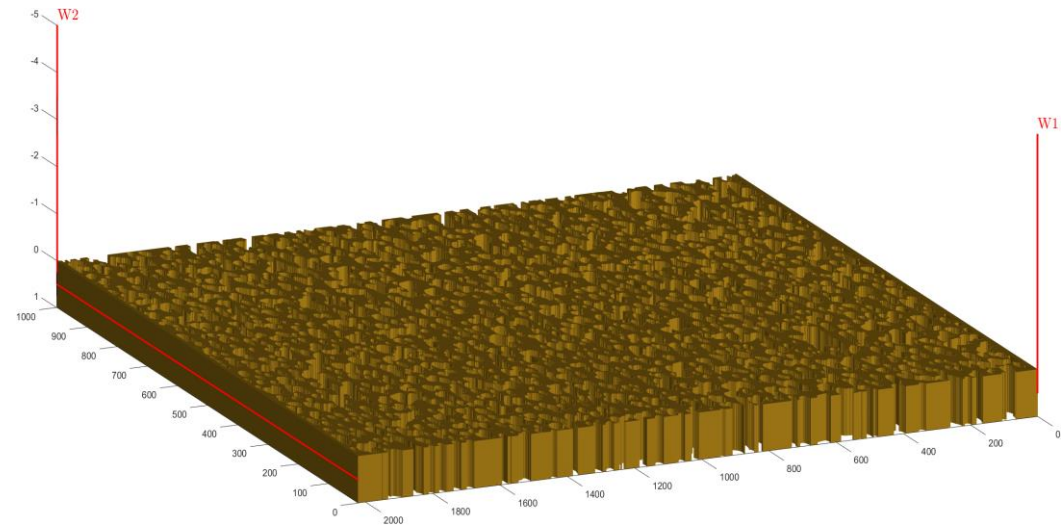

MRST Simulation Workflow

- Porous Map Generation
- Color Code Mapping
- Porosity and Permeability Map Generation
- Fluids and Initial Conditions
- **Simulation**

Parameters	Values
Initial Pressure	2.5×10^5 Pa
Porosity	0.5
Permeability	8.2 mD
Pressure at Production Well	10^5 Pa
Injection Rate	$1 \text{ m}^3/\text{s}$
Simulation Peroid	40000 s
Simulation Step	100 s

Parameters used for simulation.

Results : Simulation

CO2 Injection: Uniform permeability and porosity

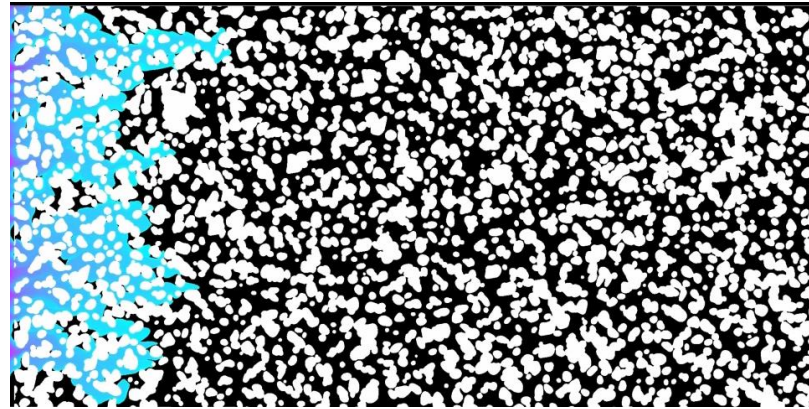

Figure. Heterogenous porous network

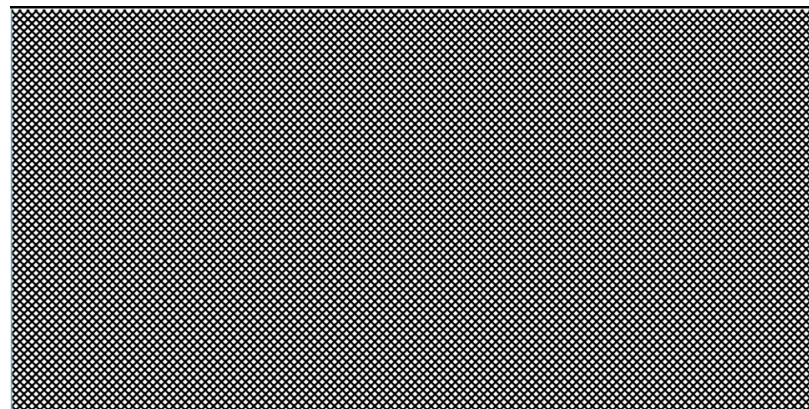

Figure. Homogenous porous network

Results : Simulation

CO₂ Injection: Permeability variation

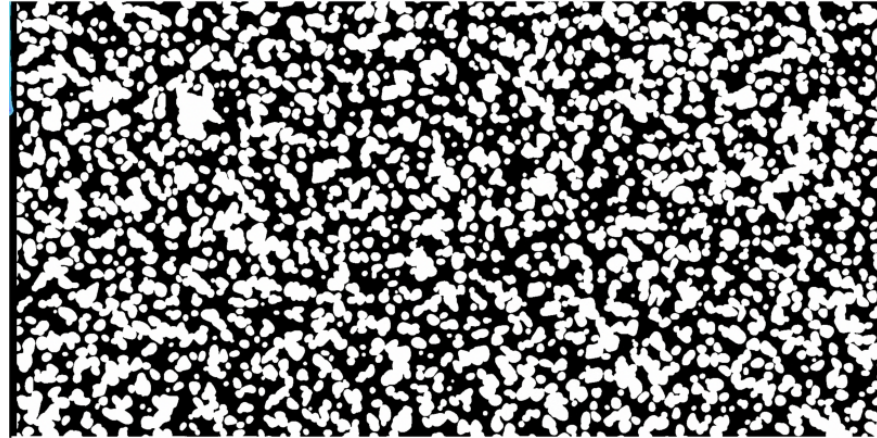

Figure. Heterogenous porous network.

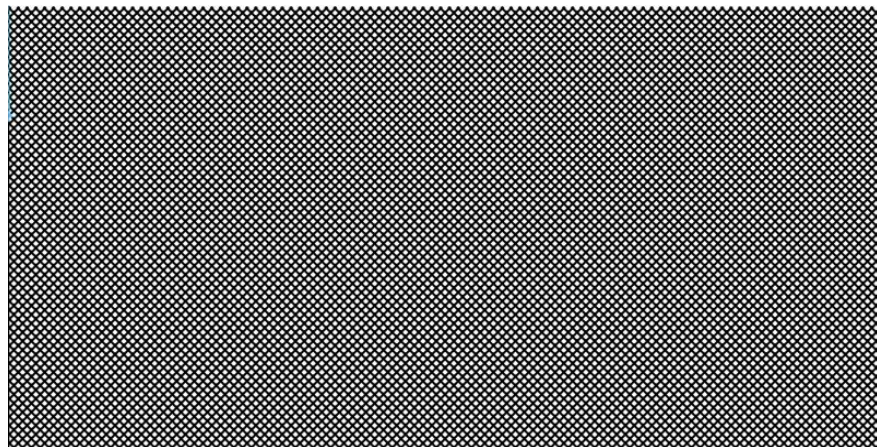
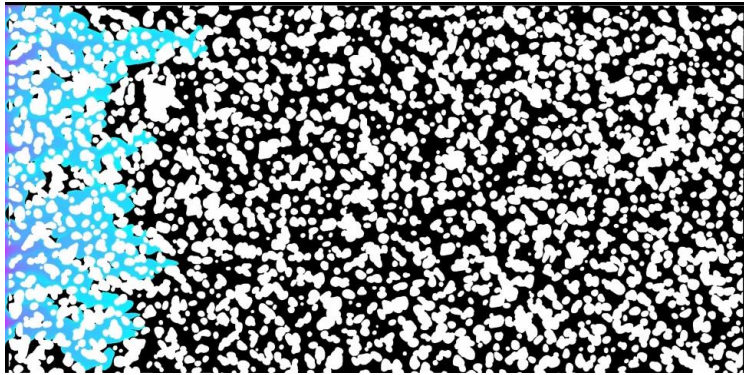
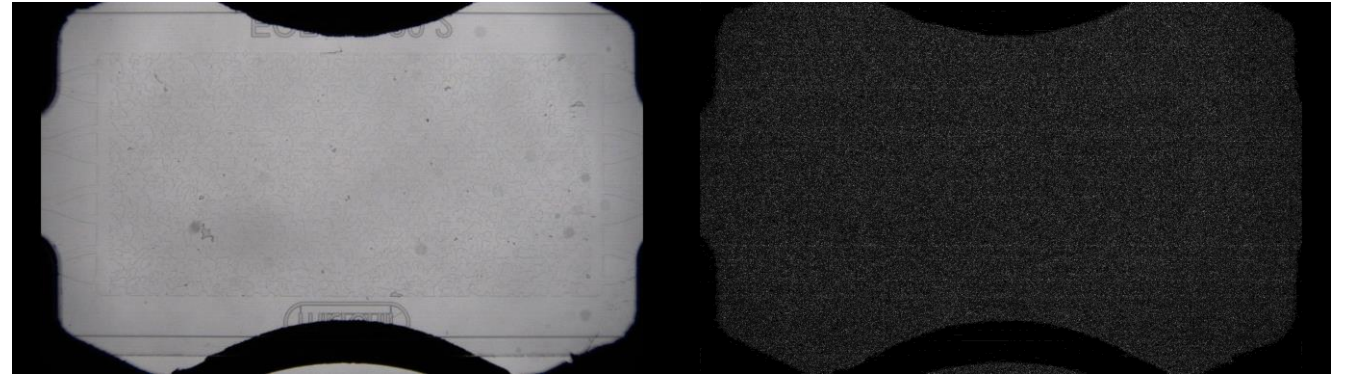

Figure. Homogenous porous network.

Experimental validation with simulation



a) Simulation



a) Experiment

Figure. Heterogenous porous network.

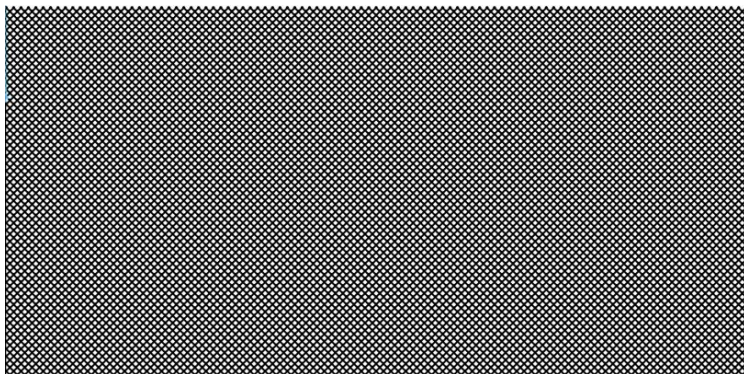

a) Simulation

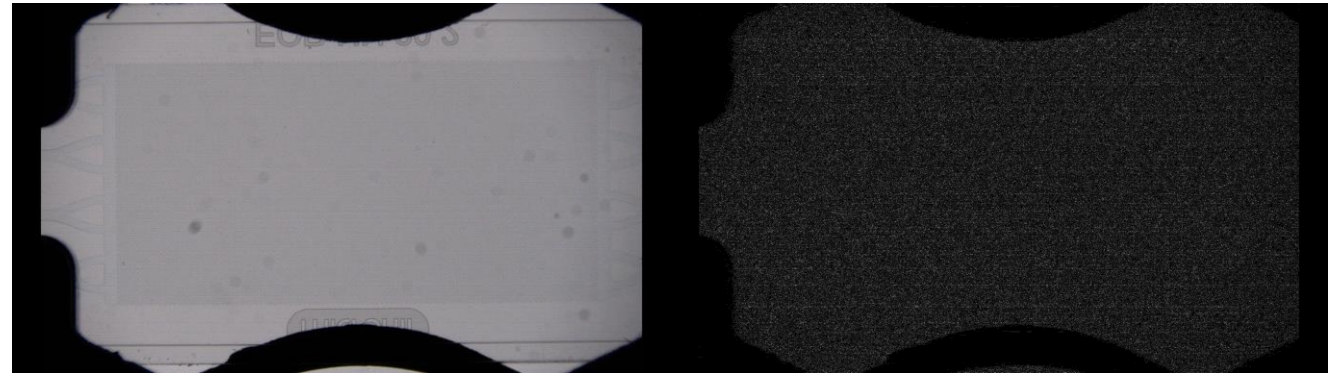

a) Experiment

Figure. Homogenous porous network.

- Replicate changes in permeability and porosity of the porous network caused by salt crystal formation through computational simulations.
- Assess the impact of pressure variations on brine displacement
- Perform experiments under high-pressure and high-temperature supercritical CO₂ conditions.
- Analyze mechanisms of salt precipitation under gaseous versus supercritical CO₂ injection.

Acknowledgement

- DigiPorFlow Group at Heriot-Watt University, Edinburgh, Scotland.

Funding: Lithuanian Research Council Funding for post-doctoral research fund, proposal registration No. P-PD-24-093.

References

- Malik, S., Makauskas, P., Karaliūtė, V., Pal, M., Sharma, R., 2024. Assessing the Geological Storage Potential of CO₂ in Baltic Basin: A Case Study of Lithuanian Hydrocarbon and Deep Saline Reservoirs. *International Journal of Greenhouse Gas Control*, Vol. 133, 104097, doi: <https://doi.org/10.1016/j.ijggc.2024.104097>.
- Malik, S., Khan, M. S., Pal, M., Gomari, S. R., Rahman, M. A., Emad W. A. S., 2024. Experimental Analysis of Geochemical Changes Caused by CO₂ Injection: A Study of Lithuanian Saline Aquifers. Paper presented at the ADIPEC, Abu Dhabi, UAE, November. doi: <https://doi.org/10.2118/222252-MS>
- Bacci, G., Korre, A., Durucan, S. (2011). Experimental investigation into salt precipitation during CO₂ injection in saline aquifers. *Energy Procedia*, 4, 440-4456, doi: 10.1016/j.egypro.2011.02.399.
- Ho, T.H.M., Tsai, P.A. (2020), Microfluidic salt precipitation: implications for geological CO₂ storage, *Lab on a Chip*, 20, 3806-3814, <https://doi.org/10.1039/D0LC00238K>
- Porous Medium (2025). In Wikipedia, https://en.wikipedia.org/wiki/Porous_medium. (Accessed on 3 September, 2025.)
- Shogenova A., Šliaupa S., Shogenov K., Šliaupienė R., Pomeranceva R., Uibu M., Kuusik R. 2009. Possibilities for geological storage and mineral trapping of industrial CO₂ emissions in the Baltic region. *Energy Procedia* 1: 2753–2760. 23.
- Yan, L., Niftaliyev, R., Voskov, D., Farajzadeh, R. (2025), Dynamics of salt precipitation at pore scale during CO₂ subsurface storage in saline aquifer, *Journal of Colloid and Interface Science*, 678 (B), 419-430, <https://doi.org/10.1016/j.jcis.2024.08.265>.